



PROOF
Revised by HA Marcomms Poole
Please review content carefully and provide feedback
Proof No: 1
Time/Date: 01-03-12



**Multi-Spectrum UV/Dual IR/VIS
Fire and Flame Detector**

Fire Sentry FS20X Detector



Features

- Patented* WideBand IR™ Infrared combined with Ultraviolet
- Detection range greater than 200 feet to 1 sq. ft. heptane fire
- Patented* Electronic Frequency Analysis
- Visible sensor for optimum false alarm rejection
- Selectable detection sensitivities
- Solar blind 90° full 100% cone-of-vision
- Dual microprocessors for reliable performance
- Real-time clock for accurate time dating of events
- FirePic™ — Up to 6 pre-fire event data storage
- Event log — Up to 200 events with date and time stamp
- Built-in RS-485 ModBus communication
- Built-in non-isolated 4-20 mA analog output (sink or source)
- Alarm, Fault and Fire Verification relays
- Automatic Optical Path and Electronic self-test
- Widest operating temperature range
- Patented* Electronics Module for components protection with plug-in terminations for easy field installation
- Two ¾" NPT or 25 mm conduit entries
- Low power consumption
- High RFI and EMI immunity
- FM approved

Benefits

- Detects hydrocarbon and non-hydrocarbon fuel fires in all environmental conditions
- Arc welding immunity
- False alarm rejection for all environmental conditions
- Minimal maintenance for trouble-free operation
- PC software and interface module (FSIM) for fault diagnostics real-time graphs (RTGs), and downloading of FirePics™ and event log
- Suitable for a wide variety of applications

Applications

- Refineries and oil production facilities
- Off-Shore platforms
- Turbine/Compressor enclosures
- Acetylene processing and storage
- Oil and Gas pipelines and pumping stations
- LNG/LPG loading and unloading facilities
- Natural Gas and CNG plants
- Ethanol, Methanol, and IPA production and storage
- Crude oil and gasoline storage and tank farms
- Aircraft hangars
- Hydrogen plants and storage
- Paint and solvent storage
- Chemical production, storage, and loading facilities
- Power plants
- Silane gas storage

*Fire Sentry Corporation Patents

The Fire Sentry FS20X is the latest generation high technology Multi-Spectrum (UV/Dual IR/VIS) Fire and Flame Detector, which is part of the FSX family of advanced technology Electro-Optical Flame detectors.



Based on the foundation of the highly successful and reliable Fire Sentry SS4 detector, the Fire Sentry FS20X detector represents a quantum leap in integrating Infrared and Ultraviolet sensing technologies. The Fire Sentry FS20X is a Multi-Spectrum and UV/Dual IR/VIS fire and flame detector with a proven UV solar-blind sensor. The Fire Sentry FS20X exhibits faster false-alarm free response to fires over a wider temperature range and with a much longer detection range compared to conventional UV/IR detectors.

Conventional and older technology UV/IR detectors, using narrow band 4.3 micron IR sensors, will not respond to smoky fires or if the detector lens is contaminated with oil and other substances since both UV and 4.3 micron signals are attenuated, obscured or absorbed by thick smoke or detector lens contaminations. Also, these old technology UV/IR detectors will not alarm to any fire if they are installed behind ordinary window glass.

The Fire Sentry FS20X detector uses advanced patented algorithms for signal processing and fire and flame analysis is designed to alarm to all types of fires in all industrial

environmental conditions. If the detector's UV signal is degraded due to heavy smoke or a contaminated lens, the Fire Sentry FS20X's patented* WideBand IR™, Near Band IR and visible sensors will still alarm to fire but at a reduced sensitivity and slower response time.

Dual microprocessors provide a high level of fail-safe operation combined with fast and reliable performance. The Master Microprocessor performs high-speed digital sampling and signal processing calculations; while the slave microprocessor handles various sensor data, performs communications, self-diagnostics and provides interface versatility; and additional memory for storing event log and FirePic™ data.

The Fire Sentry FS20X detector has a detection range in excess of 200 feet (very high sensitivity setting) for the detection of a one square-foot Heptane reference fire and has a cone of vision greater in volumetric coverage than most UV/IR detectors. This means fewer detectors can be used as compared to other manufacturers' detectors.

*Fire Sentry Corporation Patents

General Specification



General Specifications	
Field of view	90° Full 100% Cone of vision, ± 45° from on axis
Sensitivity	Very high, high, medium and low - switch selectable
Response time	3-5 Seconds to 1 sq. ft. n-Heptane fire at 100 ft. 3-10 Seconds to 1 sq. ft. n-Heptane fire at 200 ft.
Spectral sensitivity	Ultraviolet: 185 - 260 nanometers Visible: 400 - 700 nanometers Near Band IR: 0.7 - 1.1 microns Wide Band IR: 1.1 - 3.5 microns
Operating voltage	24 VDC nominal (18-32 VDC) - regulated
Power consumption	Operating: 83 mA @ 24 VDC nominal
Alarm	133 mA @ 24 VDC nominal
Heater	155 mA - additional Note: Heater will turn on at 0°F (-17°C)
Output relays	Fire Alarm: SPDT (NO / NC) - De-energised/energised, latching/non-latching Fault: SPST (NO) - normally energized, latching/non-latching Auxiliary: SPDT (NO / NC) - De-energised/energised, latching/non-latching Contacts rating: 1 amp @ 24 VDC
Analog output	0 - 20 mA stepped - source or sink user selectable
Loop resistance	50 - 400 Ohms
Communication	One of the following - user selectable: <ul style="list-style-type: none"> • RS-485, ModBus Protocol • RS-485, FireBus II • RS-485 Special (optional) • HART, Optional plug-in module
Visual indications	Blue LED: Power Red LED: Alarm Yellow LED: Fault
Temperature range	Operating: -40 to +185°F (-40 to +85°C) Storage: -67 to +230°F (-55 to +110°C)
Humidity range	5 to 95% relative humidity, non-condensing
Vibration	Meets or exceeds MilSpec 810C Method 514.2, Curve AW12
Wiring	14 AWG (2.5 mm ²) to 22 AWG (0.326 mm ²); shielded cable recommended
Conduit entries	Standard: Two 3/4" NPT or two M25
Enclosure materials	Copper-free powder coated aluminum or 316 stainless steel
Enclosure type	NEMA 4 and 4X, IP66
Certifications	FM: Class I, Div. 1 & 2, Groups B, C, & D Class II, Div. 1 & 2, Groups E, F, & G Class III CE: Complies with EN6000-6-4 & EN50130-4
Shipping weight	Aluminum: 3.6 lbs (1.6 kg) Stainless Steel: 7 lbs (3.2 kg)
Mounting	Swivel bracket assembly - optional
Warranty	Three years from date of shipping

General Dimensions
Side and Back Views
(All Dimensions in Inches)

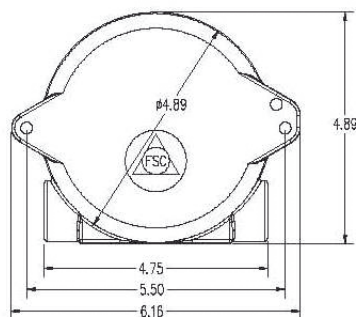
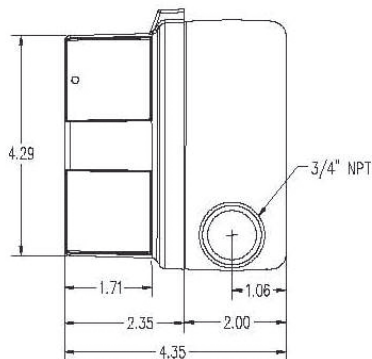

Our Product Range



Fixed Gas Monitoring

Honeywell Analytics offers a wide range of fixed gas detection solutions for a diverse array of industries and applications including: Commercial properties, industrial applications, semiconductor manufacturers, energy plants and petrochemical sites.

- » Detection of flammable, Oxygen and toxic gases (including exotics)
- » Innovative use of four core sensing technologies – paper tape, electrochemical cell, catalytic bead and infrared
- » Capability to detect down to Parts Per Billion (ppb) or Percent by Volume (%v/v)
- » Cost effective regulatory compliance solutions

Portable Gas Monitoring

When it comes to personal protection from gas hazards, Honeywell Analytics has a wide range of reliable solutions ideally suited for use in confined or enclosed spaces.

These include:

- » Detection of flammable, Oxygen and toxic gases
- » Single gas personal monitors – worn by the individual
- » Multi-gas portable gas monitors – used for confined space entry and regulatory compliance
- » Multi-gas transportable monitors – used for temporary protection of area during site construction and maintenance activities

Technical Services

At Honeywell Analytics, we believe in the value of great service and customer care. Our key commitment is providing complete and total customer satisfaction. Here are just a few of the services we can offer:

- » Full technical support
- » Expert team on hand to answer questions and queries
- » Fully equipped workshops to ensure quick turnaround on repairs
- » Comprehensive service engineer network
- » Training on product use and maintenance
- » Mobile calibration service
- » Customised programmes of preventative/corrective maintenance
- » Extended warranties on products

Find out more

www.honeywellanalytics.com

Contact Honeywell Analytics:

Europe, Middle East, Africa, India

Life Safety Distribution AG
Weiherallee 11a
CH-8610 Uster
Switzerland
Tel: +41 (0)44 943 4300
Fax: +41 (0)44 943 4398
India Tel: +91 124 4752700
gasdetection@honeywell.com

Americas

Honeywell Analytics Inc.
405 Barclay Blvd.
Lincolnshire, IL 60069
USA
Tel: +1 847 955 8200
Toll free: +1 800 538 0363
Fax: +1 847 955 8210
detectgas@honeywell.com

Asia Pacific

Honeywell Analytics Asia Pacific
#508, Kolon Science Valley (I)
187-10 Guro-Dong, Guro-Gu
Seoul, 152-050
Korea
Tel: +82 (0)2 6909 0300
Fax: +82 (0)2 2025 0329
analytics.ap@honeywell.com

Technical Services

EMEA: HAexpert@honeywell.com
US: ha.us.service@honeywell.com
AP: ha.ap.service@honeywell.com

Please Note:

While every effort has been made to ensure accuracy in this publication, no responsibility can be accepted for errors or omissions. Data may change, as well as legislation, and you are strongly advised to obtain copies of the most recently issued regulations, standards, and guidelines. This publication is not intended to form the basis of a contract.

H_Fire Sentry_FS20X_DS01125_V1_EMEA1

03/12

© 2012 Honeywell Analytics

Honeywell