

珠海福斯特
www.fst-tech.com

SPM Flex

Product Overview

产品简介

2016

Honeywell

SPM Flex

Honeywell

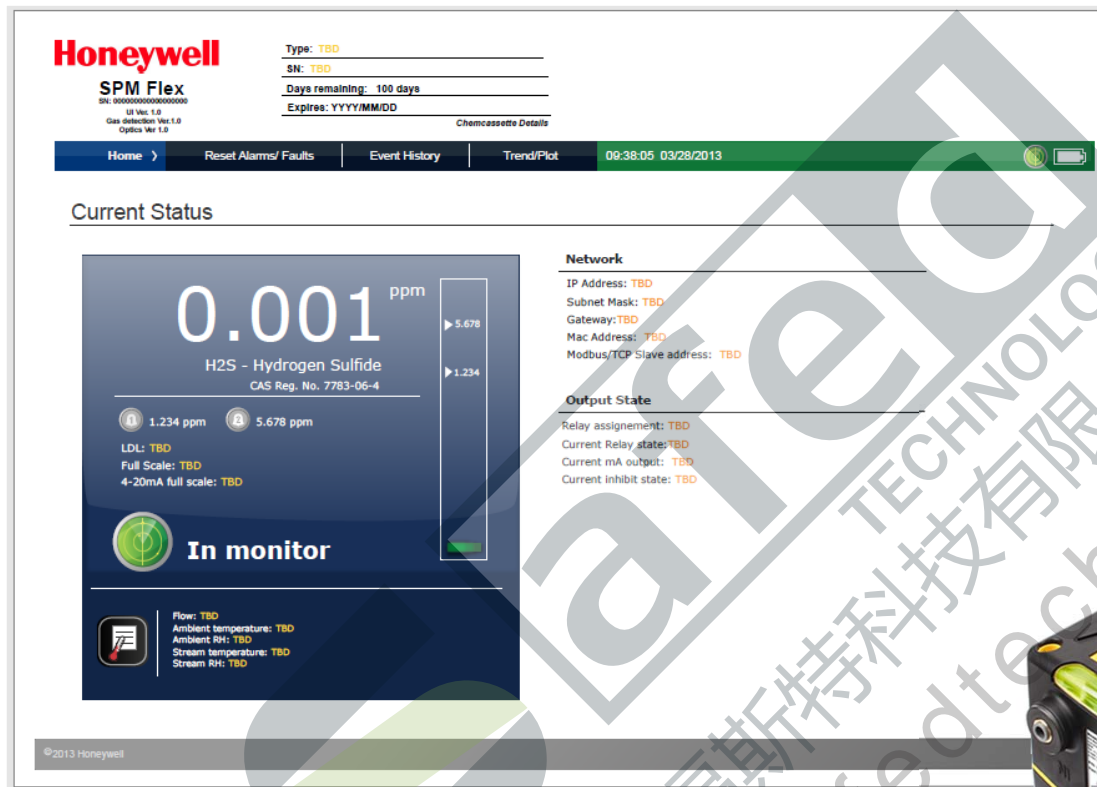

Newest Member Of The Honeywell Analytics Product Family

Overview

Honeywell

- **ChemCassette® Tape-Based Gas Detector (Chemcassette 纸带探测器)**
 - Advanced Self Monitoring Optics Design (先进的光头自检设计)
 - Intelligent Cartridge: RFID Has All Gas Information; Calibration Built-In (智能: 无线射频识别所有气体信息; 标定数据嵌入)。
- **Available In Fixed Or Portable Configurations (可固定安放或便携使用)**
 - Fixed Includes Wall Bracket (墙面安装, 现场固定使用)
 - Portable Includes Handle And Shoulder Strap; Optional Wand (便携方式包括手持和肩背, 另附手持把手选件)
- **Intuitive, User Friendly Operation (操作顺畅, 直观)**
 - Full Color LCD, Color Coded LED Status Bar → Status From Distance (全彩色LCD屏幕, 彩色LEC状态栏 → 距离状态)
 - Basic Operation Largely Automated → Minimal Training Required (大部分的常规操作都是自动完成的 → 仅需简单培训即可上手)
- **Purpose Built (用途)**
 - Cleanroom Compatible Materials & Surface Design; Easy To Use In Hazmat Gear (设备的材料和外观设计适合在洁净房使用)
 - Modular Design: Main Parts Serviceable In 5 min (模块化设计, 主要零部件5分钟内实现替换)

Newest Member Of The Honeywell Analytics Product Family

New Standard In Portable Gas Detection

便携式探测器的新标准

Honeywell

- **Maximum Flexibility 灵活自由**
 - Wide Variety Of Communications Options (多种通讯方式)
 - Industry Leading Gas Selection; Up To 90 Day Tapes (工业主要气体所用的纸带长30天)
 - Portable & Fixed Means Less Spare Parts Needed (一机两用, 减少使用成本)
- **Advanced Capabilities, No Expertise Required (先进的性能, 简易操作)**
 - Intuitive, Easy To Use Design (操作顺畅, 直观)
 - Automatic Data Logging; Access By Web Or USB (通过web 或USB 自动数据记录)
 - RFID On Tape Sets Calibration And Flow Control (RFID 设置在纸带上, 具有流量控制功能)
- **Rugged Design For Extreme Environments (为极端环境而设计)**
 - IP65 Rated For Weather Proof Operation (IP 65 的保护)
 - Hose Down / Wipe In The Event Of Contamination (在受到污染的情况下可拆卸/ 擦拭)
 - Rugged Design Stands Up To Changes In Temperature, Moisture And Humidity (坚固的设计抵抗温湿度, 及水分的干扰)



Maximum Flexibility Portable For Low Level Toxics

针对低浓度的毒气探测器具有最大的灵活性

User Interface 用户界面

Honeywell

Device Interface

- **Intuitive Interface And Setup 直观的界面和设置**
 - Visible Up Close Or Across A Room (直观的界面切换)
 - Simple Menu, Always Active Status Bar (简易的菜单, 状态柱事实实现)



Web Interface

- **Integrated Next Generation Web Interface 集成了新一代的Web 界面**
 - PC & Mobile Access Without Special Software (无需特殊软件, 即可联系电脑和移动设备)
 - Consistent Brand Language (Colors, Icons) (协调的语言, 色彩, 图标)

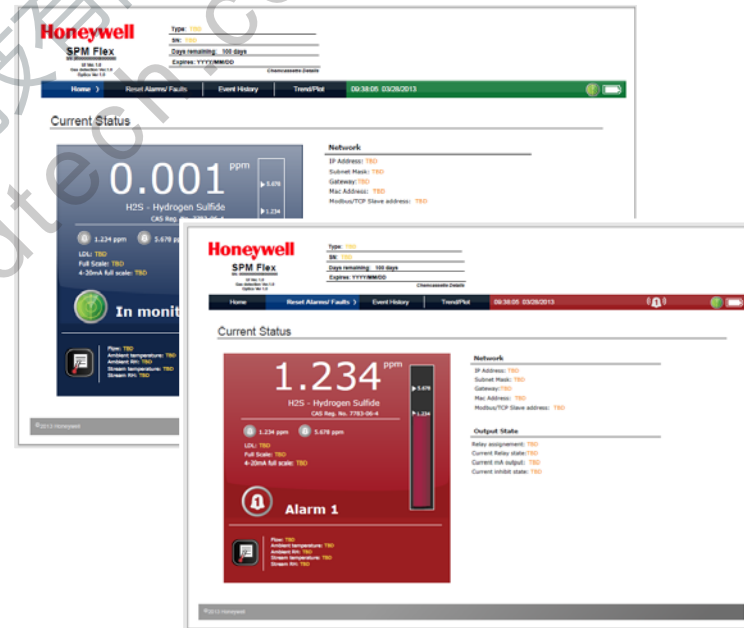

Best In Class User Experience 最好的用户体验



Extreme Accuracy For Extreme Gases
高精度探测气体浓度

Key Components: Top Assembly

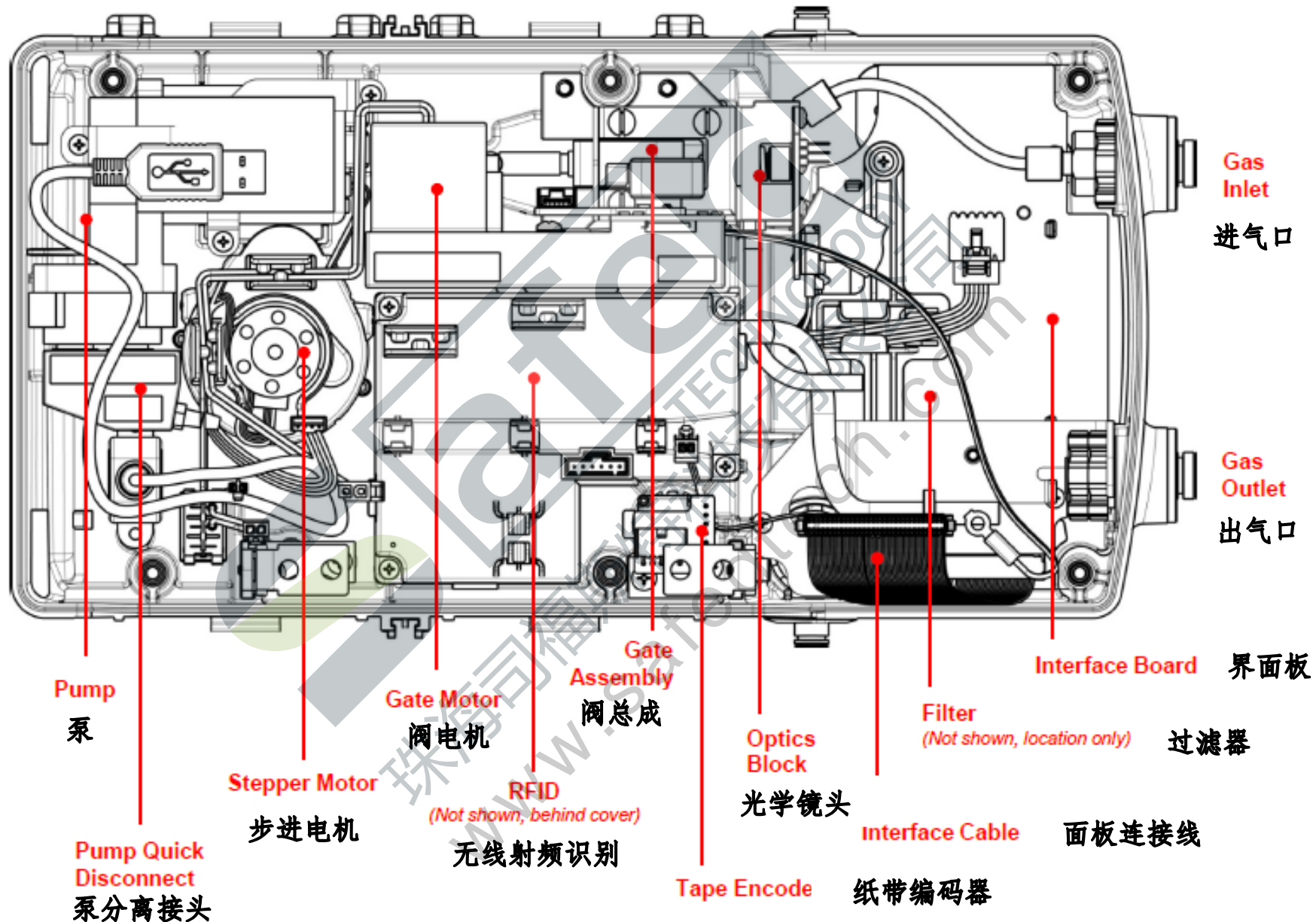

Key Components: Bottom Assembly

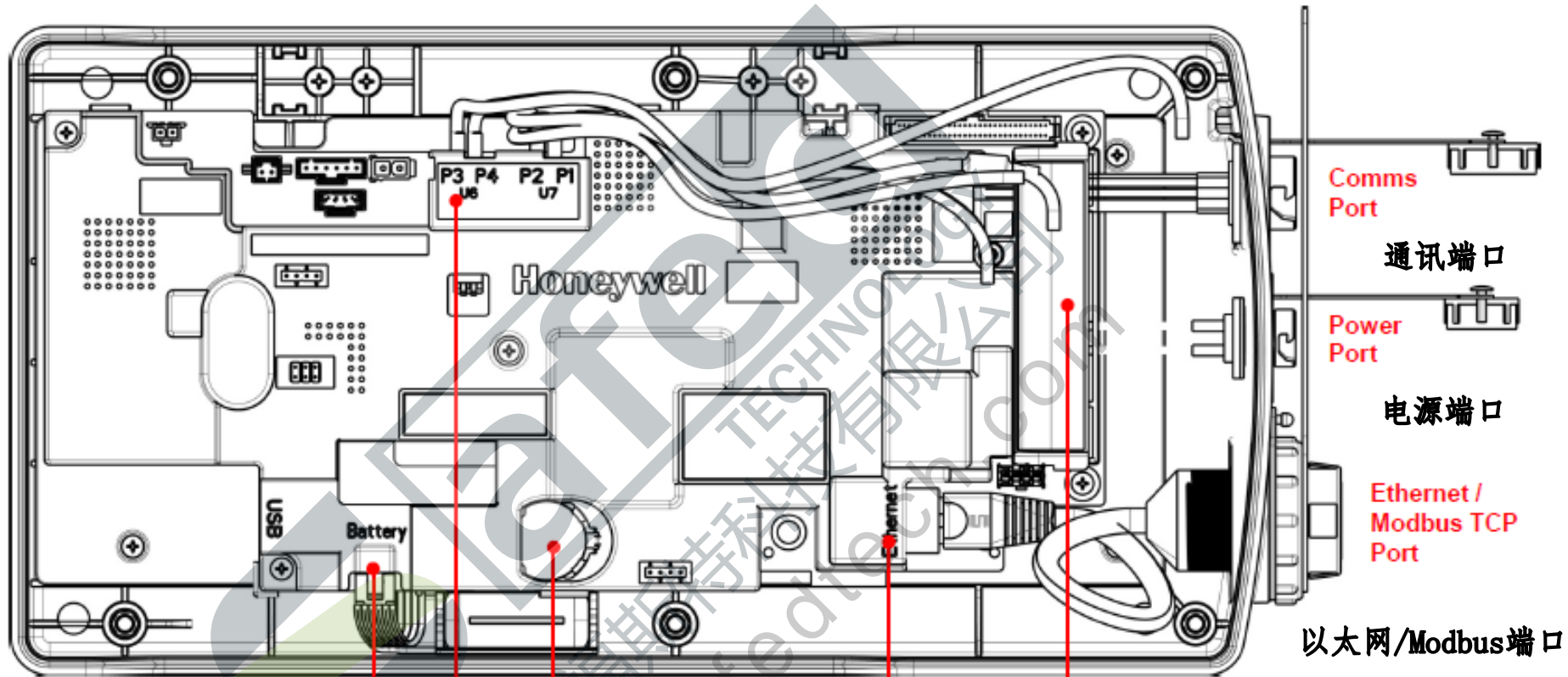

系统电池连接头

Main Battery Connector

Coin Battery
纽扣电池

Flow & Leak
Sensors

流量&泄露检测元件

Ethernet
以太网接口

Communication
And Power Terminals
通信和电源接线端子

以太网/Modbus端口

Comms
Port

通讯端口

Power
Port

电源端口

Ethernet /
Modbus TCP
Port

Gas List*

Honeywell

Phase	Family	Gas	TLV	SPM Flex	CC	Phase	Family	Gas	TLV	SPM Flex	CC
Phase-A	Hydrides	AsH3		2.5-500ppb	XP Hyd	Phase-B	COCl2	COCl2	100 ppb	7-1000 ppb	XP COCl2
		AsH3-LL	5 ppb	0.5-50 ppb				COCl2-HL	100 ppb	7-4000 ppb	XP COCl2
		PH3	300 ppb	3-3000 ppb	XP Hyd		Diisocyanates	TDI	1 ppb	1-60 ppb	OI
		B2H6	100 ppb	10-1000 ppb	XP Hyd			MDI	5 ppb	2-60 ppb	OI
		SiH4	5 ppm	0.5-50 ppm	XP Hyd			HDI	5 ppb	2-60 ppb	OI
		SiH4-LL	5000 ppb	50-5000 ppb	XP Hyd		Hydrazines	N2H4	10 ppb	10-1000 ppb	Hydrazines
		GeH4	200 ppb	50-2000 ppb	XP Hyd			MMH	10 ppb	3-2000 ppb	Hydrazines
		H2Se	50 ppb	5-500 ppb	XP Hyd			UDMH	10 ppb	3-5000 ppb	Hydrazines
		H2S	1 ppm	0.5-50 ppm	XP Hyd		HCN	HCN	4.7 ppm	0.5-30 ppm	HCN
	H2S-LL	1000 ppb	1 - 2000 ppb	XP Hyd	SO2			SO2	0.25 ppm	25-2500 ppb	SO2
	Mineral Acids	HF	0.5 ppm	0.2-20 ppm			XP MA	SO2-LL	0.25 ppm	5-250 ppb	SO2
		HF-LL	500 ppb	20-2000 ppb	XP MA		O3	O3	100 ppb	10-1000 ppb	O3
		HCl	2 ppm	0.2-20 ppm	XP MA			H2O2	H2O2	100 ppb	0.1-3 ppm
		HCl-LL	2 ppm	20-2000 ppb	XP MA						
		HBr	2 ppm	0.2-20 ppm	XP MA						
		HBr-LL	2 ppm	20-2000 ppb	XP MA						
	Oxidizers	BF3	1 ppm	0.1-10 ppm	XP MA						
		Cl2	0.5 ppm	0.035-5ppm	F2 CC						
		Cl2-LL	500 ppb	7-2000 ppb	F2 CC						
		Cl2	0.5 ppm	0.05 - 5ppm	XP CC						
		Cl2-LL	500 ppb	5 - 2000 ppb	XP CC						
		F2	1 ppm	0.06-10 ppm	F2 CC						
		NO2	0.2 ppm	0.5-30 ppm	F2 CC						
	Amines	ClO2	100 ppb	50-1000 ppb	F2 CC						
		NH3	25 ppm	1-150 ppm	XP NH3						
		NH3-LL	25 ppb	0.05 - 10 ppm	XP NH3						
		DMA	5 ppm	0.5-50 ppm	XP NH3						
		TDMAT	n/a	0.1 -10 ppm	XP NH3						
	TMA	5 ppm	0.5-50 ppm	XP NH3							

Phase B Gases Estimated To Be Available Mid 2015

B组气体预估2015年中期阶段可用

* Gas List / Detection Levels Subject To Change

Industry Leading Gas Selection 工业领域主要的气体选择

Portable Accessories



Sample Wand Kit

SPMF-WAND

For use with portable units, the sample wand kit enables users to pinpoint pesky leaks, and the integrated holder within the handle provides a convenient way to install inline filters.

样气探测杆
SPMF作为便携式使用时，样气探测杆能够精确探测泄露点，且把手处集成了一个更换很方便的过滤器。



无尘车间使用肩带
选用可适应无尘车间的材料制成，肩带使SPM Flex 更便于携带。
由于肩带使用需要，把手上设有连接扣。



Cleanroom Suitable Strap

SPMF-STRP

Made from cleanroom suitable materials, the SPM Flex STRAP is a great way to transport the unit.

Note that the handle accessory is required (SPMF-HNDL) due to the connection points required.



Easily Serviceable 便捷的维护

Honeywell

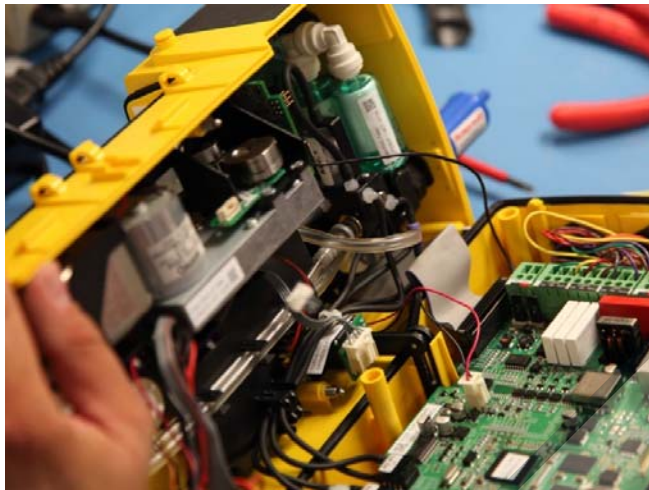

- **Designed With Serviceability In Mind**

- **Highly user serviceable:** Pump, filters, stepper motor, and gate motor are all **serviceable by the end user in under 5 minutes**.

便于维护的设计

熟练用户维护：泵，过滤器，步进电机和阀电机都可以由终端用户在5分钟内维护。

* *Comprehensive inspection, cleaning, and systems tests are recommended periodically, depending on usage, site conditions, and gases monitored.*

Description	Maintenance Intervals (months)		
	3	6	12
Authorized Honeywell preventive maintenance			●
Replace the end-of-line filter	●		
Check pump			●*
Check for system leaks		●	
Verify optic system response	●		
Replace internal filters			●
Check stepper motor	as needed		
Check gate motor	as needed		
Clean the exterior surfaces	as needed		
Replace real-time coin battery	3 years or as needed		
Replace main battery	return the detector to Honeywell Analytics		

*or as needed

Certifications 证书

Honeywell

Certification	Description	SPM Flex	SPM	TLD
Safety – N. America	UL Certified for USA and Canada to UL 61010-1, 3rd Edition and CAN/CSA-C22.2 No. 61010-1, 3 rd Edition	●		
Safety – Europe (Unit)	UL IEC CB Report for EN61010 3rd Edition (European LVD)	●		
EMC	UL Tested and Certified in: USA, Canada, Europe, Australia, Korea, Taiwan, Singapore, Malaysia, and China	●		
Radio Transmission	UL Tested and Certified in: USA (FCC), Canada (IC), Europe (R&TTE), Australia, Korea, Taiwan, Singapore, Malaysia, and China	●	N/A	N/A
Environmental	Meets all applicable European Directives including ROHS, WEEE, Packaging Directive, Battery Directive and REACH	●		
Safety	Intertek Certified for USA to UL 61010B-1, 1st Edition		●	
Safety – N. America (Battery)	UL Tested and Certified to UL 2054, 2nd Edition, UL 60950-1, 2nd Edition, and CAN/CSA-C22.2 No. 60950-1-07	●	N/A	N/A
Safety – Europe (Battery)	UL Report for IEC 62133, 1st Edition and EN 62133:2003	●	N/A (Lead Acid)	N/A (Lead Acid)

(● 表示已经获得)

SPM Flex VS TLD-1

SPM Flex	TLD
----------	-----



Size	13.2"L x 7.2"W x 6.4"T	TLD 8"x8"x 9"
Weight	~10.5 lbs with handle	TLD ~9lbs
Display	Full Color LCD	Single Line LCD
Alarm	LED / 90+DB buzzer	Light/Audible
Comms	4-20mA, 3x Relays, Modbus TCP/IP, Web	2x Relays
Data Storage	Rolling 90 Days	External via 4-20mA
Op Temp	0 to 40C*	0 to 40C*
Weatherproof	Yes, IP65 Rated	No
Gases	~30 Gases, Custom Lvl's	~30 Gases, 50+ CKs
Tape Lengths	Up to 90 day	15' day
Haz Areas	Not Currently	No
Tape Saver	Duty Cycle In Process	no
Impact Rating	5J	

Advantage 优势
Easy To Use 易用性
Communications 多样化通信方式
Superior User Experience 优越的用户体验
Easy To Service 服务方便
Install Flexibility 安装的灵活性

Competitors VS other与其它品牌产品比较

Honeywell

SPM Flex

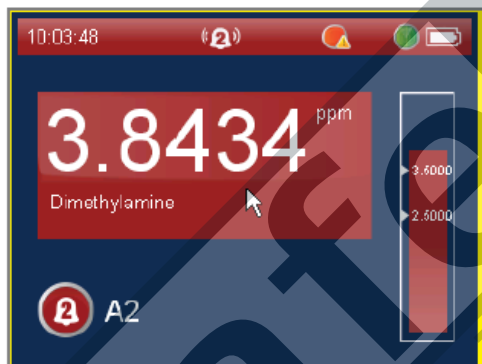

CLPX



兼容便携与固定方式
完备的输出通信功能
超大LCD 全彩显示屏
超长电池使用时间和寿命

Quick Start Up 快速开机

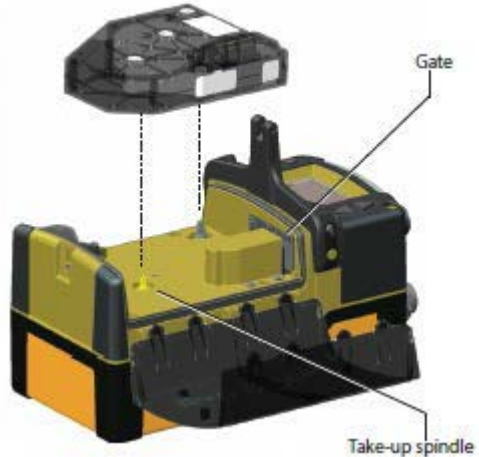
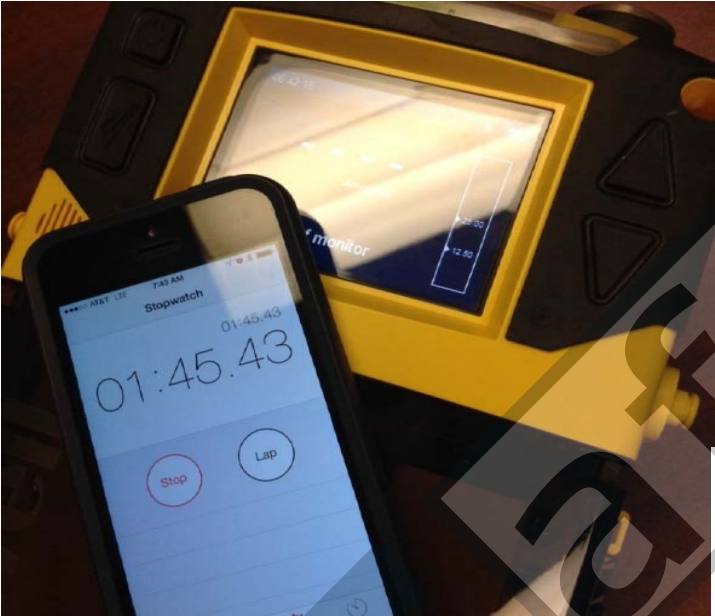

可以在2分钟内快速响应

Ready To Go In Under 2 Min So You Can Respond Quickly

Easy To Use 操作简单

Honeywell

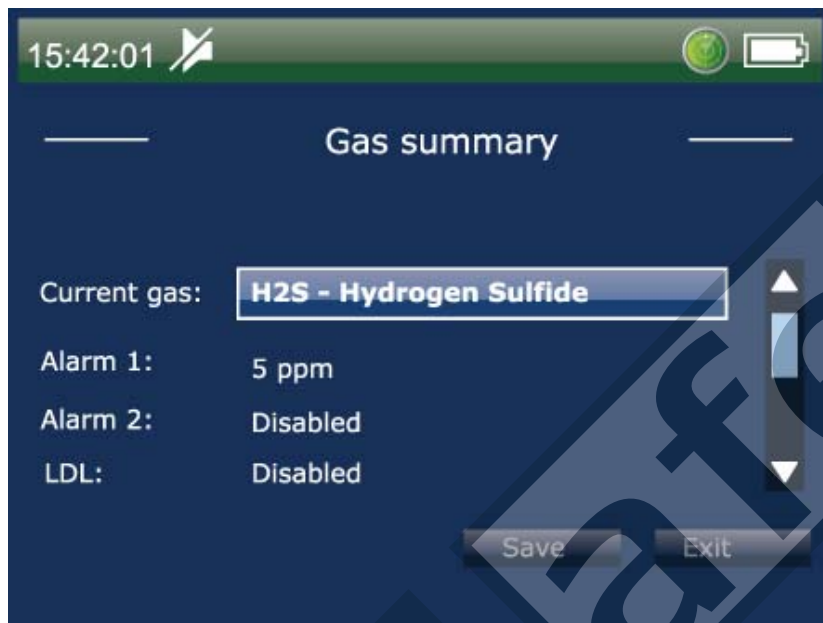

• Maximum Automation

- RFID identifies all available gases for that tape, while flow control and alarm levels are automatically populated
- When gas calibrations are added or changed, you always have the most up-to-date version keeping you safe

• Intuitive Operation

- Gas concentration bar gives clear status vs. alarm levels
- Common language menus, universal R/Y/G status indication

高程度自动化

-- 无线射频识别所有气体纸带，自动输入各报警级别对应气体流量。
 -- 当气体种类增加或者改变时，相对应版本数据会自动更新以确保您的安全。

直观的操作

-- 气体浓度条清晰的告知浓度状态和报警等级。
 -- 多语言菜单，通用R/Y/G状态指示

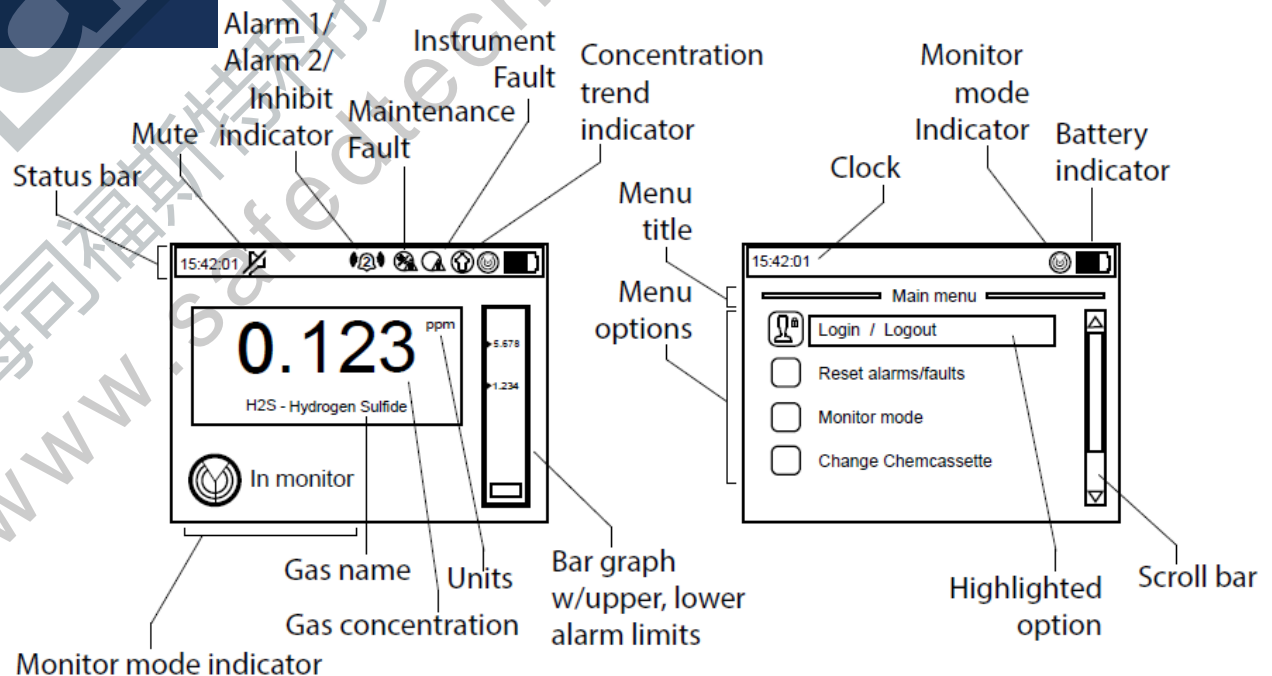

Clear Interface 清晰的操作界面

Honeywell



Local LCD

The crisp, full color LCD display is easy to read and interpret, no matter what the conditions.

LED Status Bar

Thanks to a crisp display and a color-coded LED bar on top of the SPM Flex, you can see alarm status, gas concentration and other data, even from across the factory floor.



Is your current device easy to read?

Does it have clear notifications for faults and warnings?

Can you access it from anywhere or reset / acknowledge faults and alarms?

How much time is wasted looking for the point of gas detection with an issue?

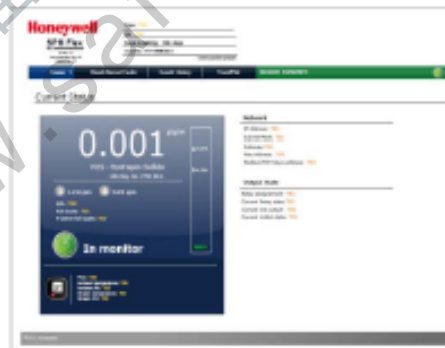

Web Page Access

Know what your units is doing in real time - even if you're remote - with full webpage access built right in, leveraging the same design language as the unit.

Crisp And Clear From Up Close Or Far Away

Multiple Security Levels 多级安全等级

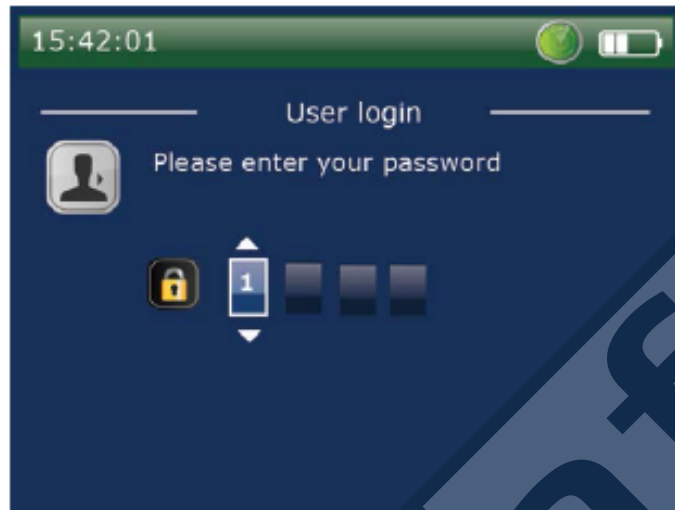

Can multiple personal access the unit?

Are you sure that everyone working with a piece of equipment know how to use it?

可以多人进入系统吗?

您确定每个人知道如何使用设备吗?

Access Rights	Security Levels					
	0 Not Logged In	1 Routine Maintenance	2 Advanced Maintenance	3 Power User	4 Admin	5 Factory Service
Log in/log out	●	●	●	●	●	●
Reset alarms and faults	●	●	●	●	●	●
Review mode	●	●	●	●	●	●
Limited maintenance access		●	●	●	●	●
Change Chemcassette (to same type)		●	●	●	●	●
Testing			●	●	●	●
Maintenance			●	●	●	●
Limited setup			●	●	●	●
Full setup				●	●	●
Change Chemcassette (to any type)				●	●	●
Security					●	●
Program update					●	●
Factory service menu (Honeywell personnel only)						●

Security Levels Help Protect Unauthorized Or Unsafe Access

New Standard In Portable Gas Detection

Honeywell

- Maximum Flexibility 高灵活性
 - Wide Variety Of Communications Options
 - Industry Leading Gas Selection; Up To 90 Day Tapes
 - Portable & Fixed Means Less Spare Parts Needed
 - 通信方式多样选择
 - 涵盖工业主流气体; 提供可达90天的纸带
 - 不需要过多的备件
- Advanced Capabilities, No Expertise Required 高性能, 便于操作
 - Intuitive, Easy to Use Design
 - Automatic Data Logging; Access By Web Or USB
 - RFID On Tape Sets Calibration And Flow Control
 - 直观设计, 易使用
 - 自动记录数据
 - RFID在纸带上设置校准和流量控制
- Rugged Design For Extreme Environments
 - IP65 Rated For Weather Proof Operation
 - Hose Down / wipe In The Event Of contamination
 - Rugged Design Stands Up To Changes In Temperature, Moisture And Humidity
 - IP65防护等级, 可在恶劣天气下使用
 - 在污染环境中可以冲洗擦拭
 - 坚固耐用的设计能够在温度、水分、湿度环境下自我调节



Maximum Flexibility Portable For Low Level Toxics